



## Paint Marks - Four Speed Toploaders - The Basics

### Some Possible Supplies/ Equipment Needed for Reproducing Marks:

- Paint brushes. Bristle and sponge types
- Appropriate premade stamps.
- Permanent crayon markers.
- Enamel paints
- Mixing container for custom colors.
- Cleaning products for surface and tools used for applying marks.

To continue with the series of articles related to paint markings originally applied to parts and subassemblies that make up our cars this article focuses on the subject of Ford top-loader transmissions and markings typically found applied to them.

Each transmission was assembled at a remote plant before it was shipped to one of the car assembly plants. During assembly identification, quality control and accountability steps and checks were often accompanied by the placement of a paint mark or stamp on the exterior of the transmission. In some examples we have seen a dozen or more of these markings on a single transmission. Fifty years later we still don't know the reason or purpose for every marking but through collection and study we can identify common patterns and practices of some of these repetitive markings. The purpose of this article is to share what has been collected in the hope of helping others locate markings on their transmissions and promote a better understanding of what has been found.



Please consider that paint marks will, in no way, make up for shortcomings or poor choices in a restoration or camouflage other unoriginal details. If your concerned about showing the car be aware that most classes do not require paint marks but can and will deduct for incorrectly placed or applied ones.

Being the product of human workers marks can be found a few inches off from where they will be shown in the following pages or in some cases with a stamp upside down. I've attempted to show the most typical location and orientation found on the available examples. The variations add to the character and the handmade look of these vehicles

Nothing here should replace what you find and document on your original transmission after a good and careful cleaning. The effort in this article is to help those that have or feel a need to place some of the basic paint marks on their transmissions and to offer an alternative of simply copying marks from some car they find in a magazine or online.

## Identifying Your Ford Toploader

On the passenger side of the transmission about midway between the forward mating flange mounting holes, you should find a small rectangle piece of metal. The identification tag is held to the main case with a single rivet in the forward most hole.

On the top row of printing is the identification code that typically starts with three letters following with a suffix to complete the code. On the lower line tags will have a individual serial number identifying the specific transmission of identification and quality control needs. Some examples are shown at the bottom of the page.

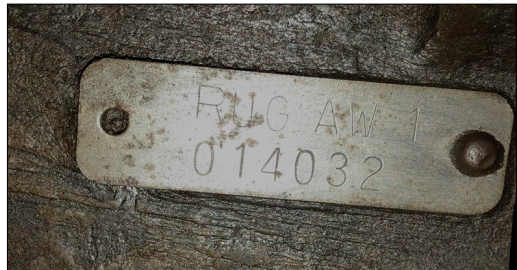
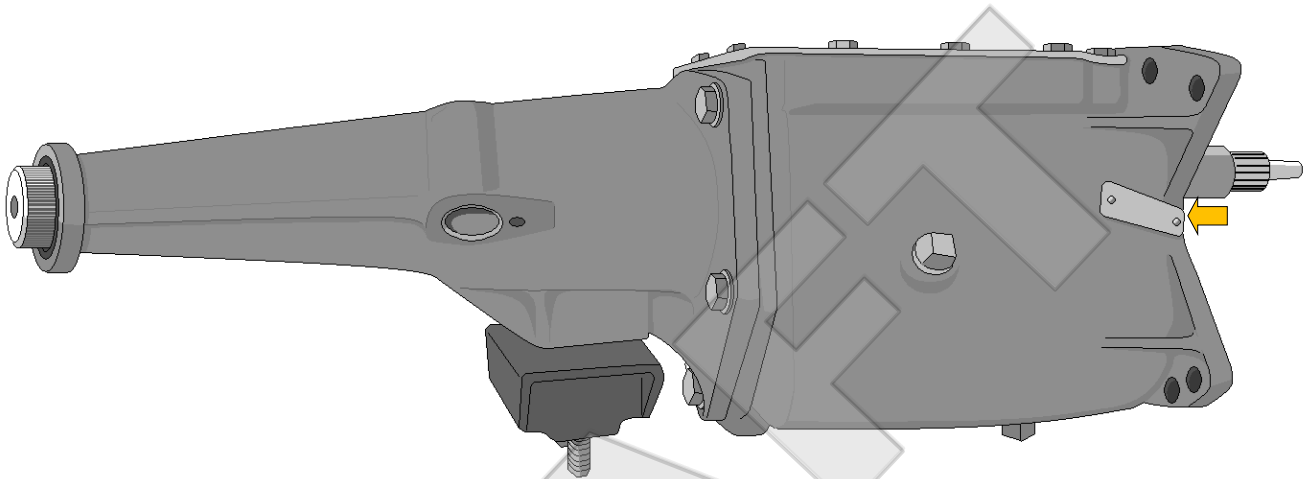



## Driver's Side - Forward Mounting Flange - Stamps & Daubs

The usage of this area of the main transmission body changed over time. In early years the area above the rear shifter shafts was used to show the casting information, this forward flange side was used as a location to indicate the assembler or inspector, a number later moved to the area

above the rear shifter studs, identification letters or later for either a simple some what square or stripe, yellow mark as shown below . These markings appear to use a school buss or strong yellow paint color.

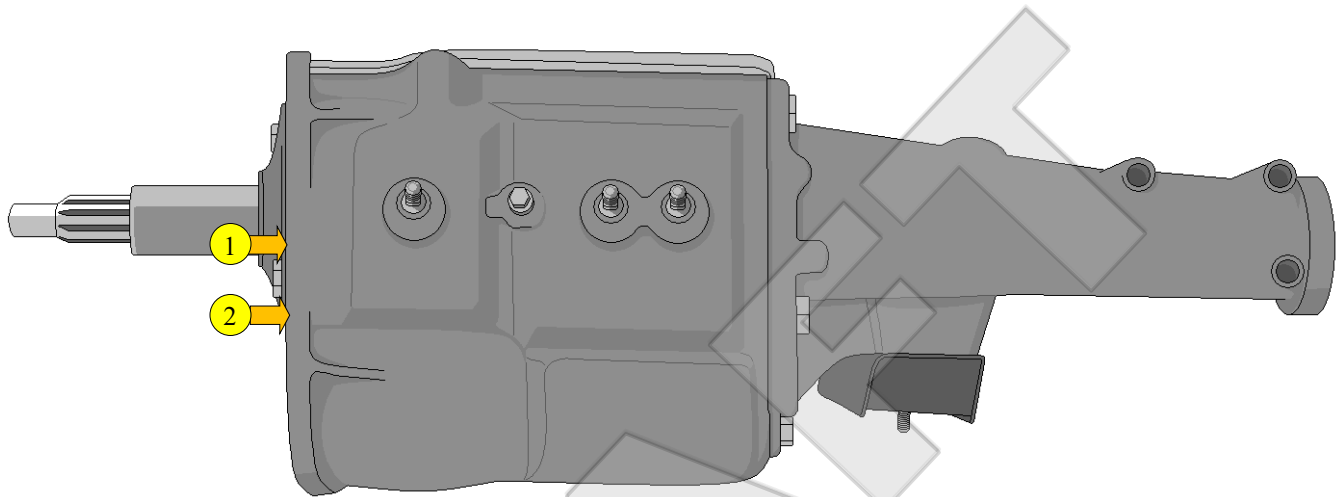

## Driver's Side - Above Rear Shifter Arms - Paint Stamp

On earlier main cases this area has the casting information while later this information was moved up around the top edge of the main case just under the top cover flange.

On later Ford toploaders we find a number indicating either assembler or inspector applied in a school bus yellow. In the following charts I refer to this number as the Assembler Number.

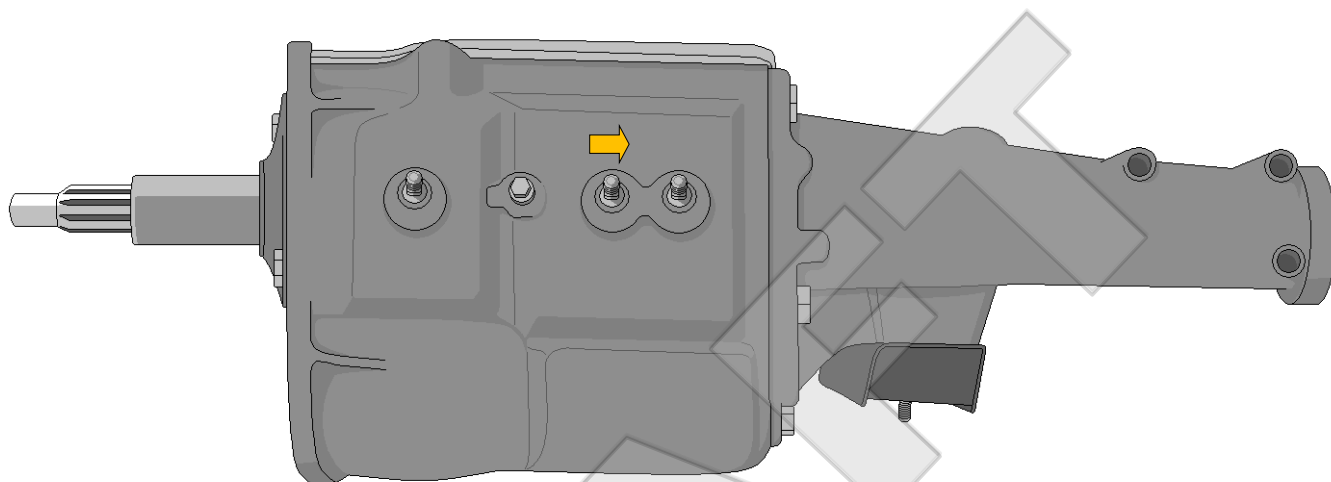



## Driver's Side - Identification Code - Hand Written

On the earlier transmissions the identification marking was applied with a medium tipped applicator. White or a possible orange color have been documented as shown in the pictures below .

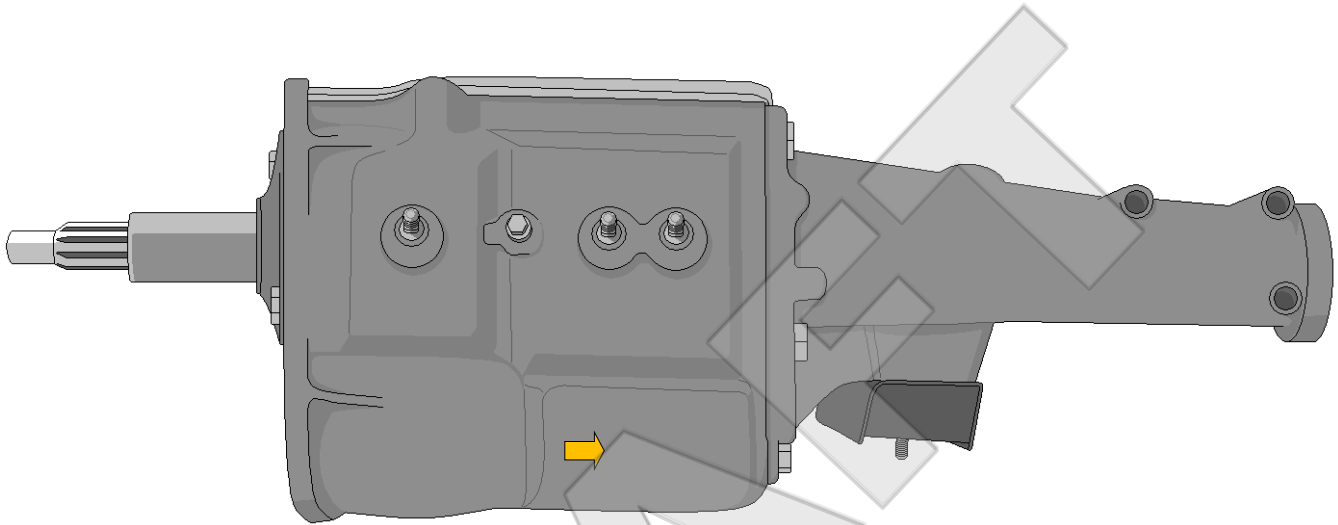

## Driver's Side - Identification Code - Paint Stamp

This surface on the drivers side of the main case typically has the identification code that matches the identification code found on the passenger side metal tag we saw earlier in this article. For this location workers used a premade stamp with a shortened version of the code.

For the stamp numerical versions (RUG-AE1, RUG-AE2 for example) of the same transmission were shortened to just G-AE for all of these variations. Color used was a school bus yellow typically. Workers usually applied the stamp to one these two semi-flat surfaces but they are much more often found at the lower of the two locations.

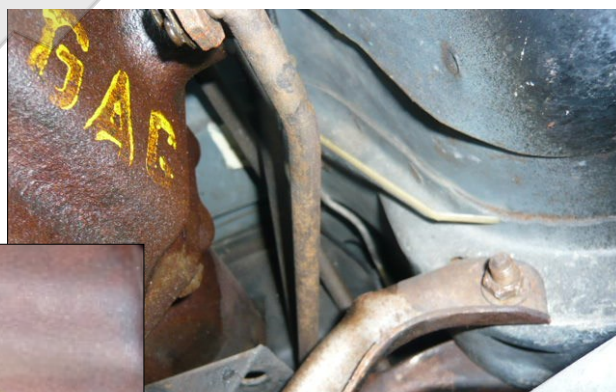
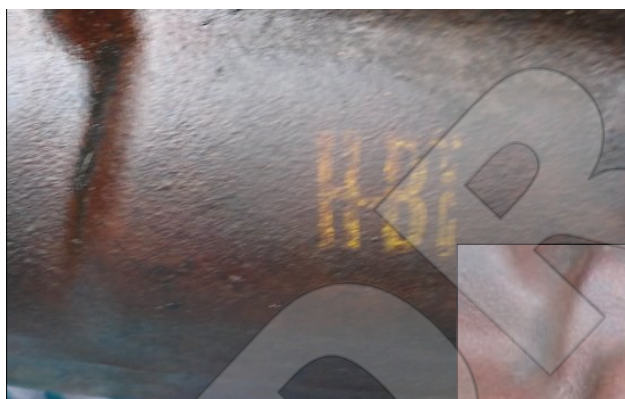
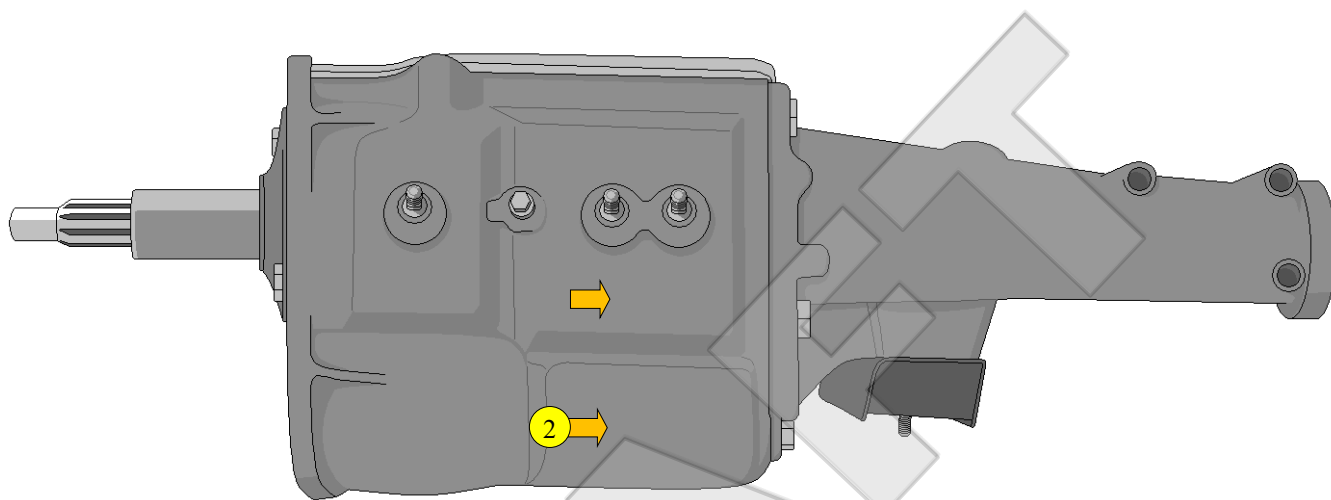



## Tail Shaft Housing - Paint Doubs

On the tail shaft housing we often find two markings. One is at or near the top surface where the speedometer opening. May have been placed to help the installers of the speedo cable locate the hole quicker.

On the bottom of the housing to the rear of the transmission mount we find a mark or marks that may have identified different housings during the assembly of the transmission as we see in other sub assembly processes.

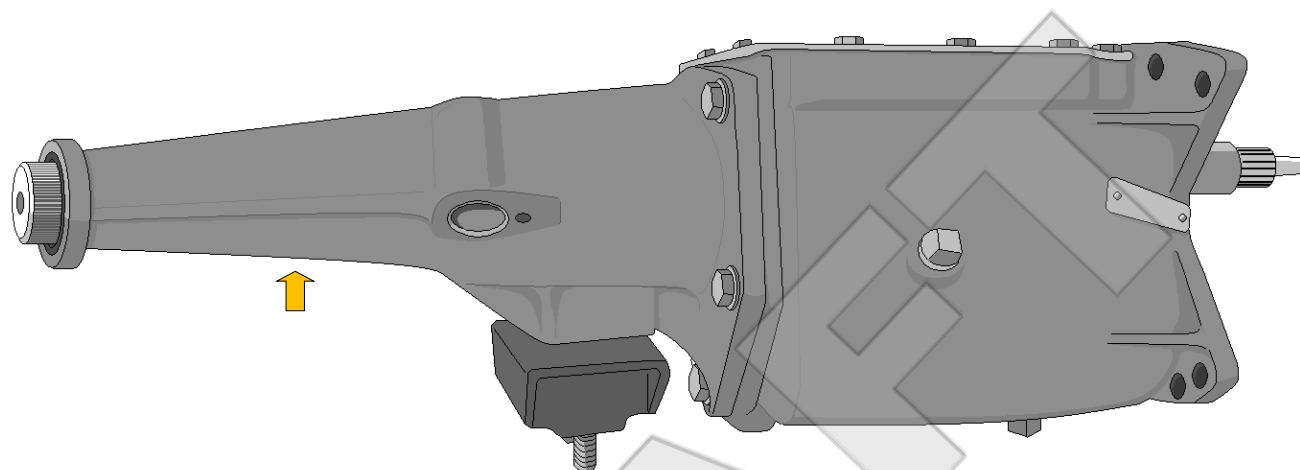

## Lower Main Body Rear - Paint - Hand Written

The main body, bottom and passenger side, are often covered by many marks, lines, letters and numbers. These have been so plentiful and varied there has been no apparent pattern or understanding.. There is one location, lower rear,

that has shown up on just about all of the examples with regularity. I choose to share so that others can look for and compare. This is typically a single digit number (one through three) shown below.

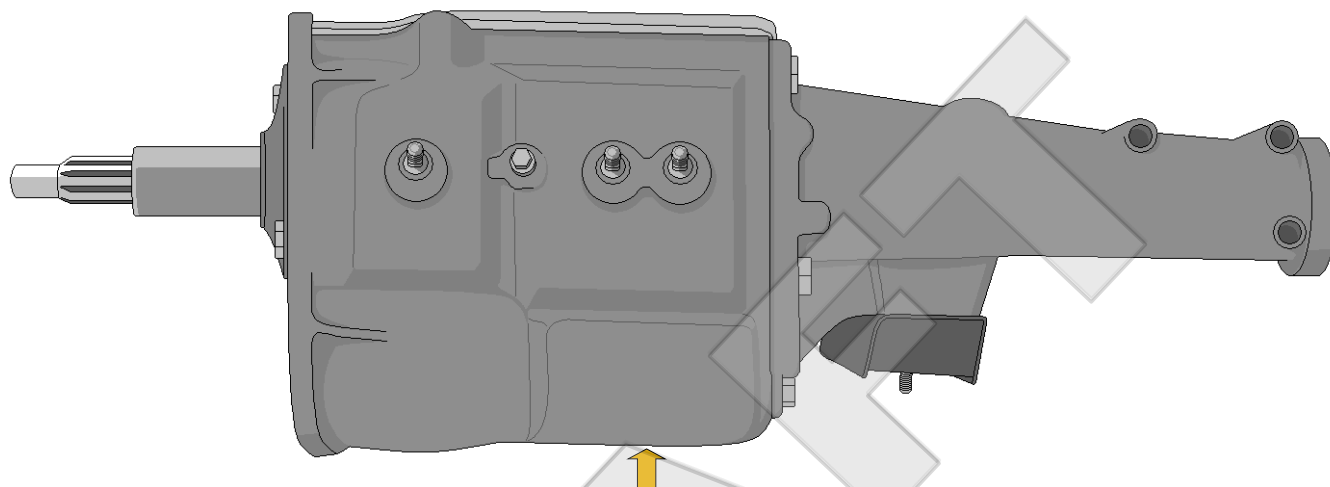



The following are charts documenting original marks found on unrestored transmission.

These findings and patterns may be useful in determining patterns and practices used at the transmission plant during each year.

TAG		FLANGE #1 Pg #3	FLANGE #2 Pg #3	SHIFTER Pg #4	DS BODY Pg #5	DS BODY 2 Pg #5	TAIL SHAFT Pg #6	LOWER BODY Pg #8
HEF BB	65	Assy #		NA				
HEF BX	65	Assy #		NA				
HEF CS	65	Assy #		NA				
HEF CV	65	Assy #		NA				
HEH BR	65	Assy #		NA				
HEH BT	65	Assy #		NA		H-BT	2 LGRN	
HEH BX	65	Assy #		NA		HBX		
HEH C	65	Assy #		NA				
HEH G	65	Assy #		NA		HG Hand		
HEH P	65	Assy #		NA		HP Hand	2 CHAR	
HEH R	65	Assy #		NA				
HEH S	65	Assy #		NA				
HEH T	65	Assy #		NA		H-T Hand & Stamp	1 YELLOW	3
HEK M	65	Assy #		NA				
HEK V	65	Assy #		NA				
HEF CV	66	Assy #		NA				
HEF CW	66	Assy #		NA				
HEK AD	66	Assy #		NA				
HEH BW	66	Assy #		NA		BW	1 YELLOW	
HEH BX	66	Assy #		NA		HBX		
HEH BX	67	Assy #		Assy #		BX	2 MEDBLU	
RAN D	67			Assy #				
RAT N, N1	67			Assy #				
RUG A	67			Assy #		GA		
RUG E, E1	67	GE		Assy #		GE		
RUG M, M1	67	GM	Yellow Mrk	Assy #		GM		3
RUG N, N1	67	GN	Yellow Mrk	Assy #		GN		
RUG S	67	?	Yellow Mrk	Assy #		GS	1 LGRN	2

## Charts - Continued

TAG		FLANGE #1 Pg #3	FLANGE #2 Pg #3	SHIFTER Pg #4	DS BODY Pg #5	DS BODY 2 Pg #5	TAIL SHAFT Pg #6	LOWER BODY Pg #8
RAN D, D1	68			Assy #				
RUG AD	68	?		Assy #				2
RUG AE	68		Yellow Mrk	Assy #			2 MEDBLU	3
RUG AU, AU1	68		None	Assy #	GAU	GAU		2
RUG E2	68			Assy #				
RUG M2	68			Assy #		GM		3
RUG N2, N3	68			Assy #		GN		
RUG S	68		Yellow Mrk	Assy #		GS	2 MEDBLU	2 3
RAN AM	69			Assy #				
RAT U	69			Assy #				
RUG AD	69		Yellow Mrk	Assy #				2
RUG AE, AE3	69		Yellow Mrk	Assy #	GAE	GAE	2 MEDBLU	2 3
RUG AG	69		Yellow Mrk	Assy #	GAG	GAG	2 CHAR or 2 YELLOW	2 3
RUG AV, AV1	69		Yellow Mrk	Assy #	GAV			2
RUG AZ	69			Assy #	GAZ	GAZ	2 GRN	1 2
RUG E E3	69		Yellow Mrk	Assy #		GE		
RUG M3	69			Assy #				
RAT BB, BB1, BB2	70			Assy #				
RUG AE, AE2, AE3	70		Yellow Mrk	Assy #	GAE	GAE	2 BLUEor 2 CHAR	2 3
RUG AV, AV1	70		Yellow Mrk	Assy #	GAV	GAV		1 2 3
RUG-AW, AW1	70			Assy #			2 MEDBLU	1 2 3
RUG AZ	70		Yellow Mrk	Assy #	GAZ	GAZ	2 GRN	2



### Reproducing Stamped Marks ((Tip)

Lack a new unlinked ink pad and your applying a paint type stamp to a part your restoring? Here is a method that has worked for me.

First you will need your chosen paint, the stamp, the part (of course) and an old magazine or catalog with shiny/glossy pages. You may need to arrange your work out of direct sunlight, spray paint will dry quickly in many conditions and consider that any breeze may blow the spray towards an unintended surface or it may blow the pages of the magazine closed before you finish your work.

Next, with everything in apply the paint over approximately a quarter of the surface of a single page..



This will provide you with areas to touch the paint stamp to and test out the amount and coverage of the stamp. Paint will pool in some areas and dry quicker in others so tap the stamp into the paint and stamp another page or a piece of paper until you get an acceptable product/outcome then restamp the stamp on the painted page as close as you can to the last time assuring that its an untouched area, then immediately onto the part that needs the

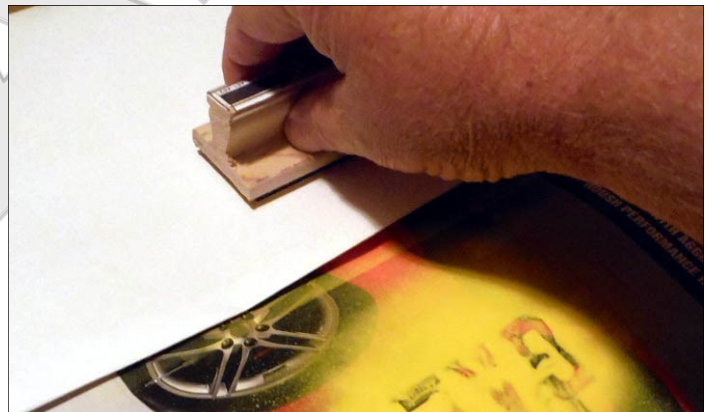

## Extra - Top Cover Plate

Hand writing applied to the cover plate appears to be inconsistent in my findings. This may suggest that it was something done by a worker working on a single shift, at the transmission or car plant, or something else.

At the time of this writing I have no examples from toploaders installed at the Metuchen with this marking which might suggest that this was an in car plant applied marking. On San Jose installed toploaders the top cover is sometimes marked with the cars second rotation number to assure that the right parts were installed on the right car.

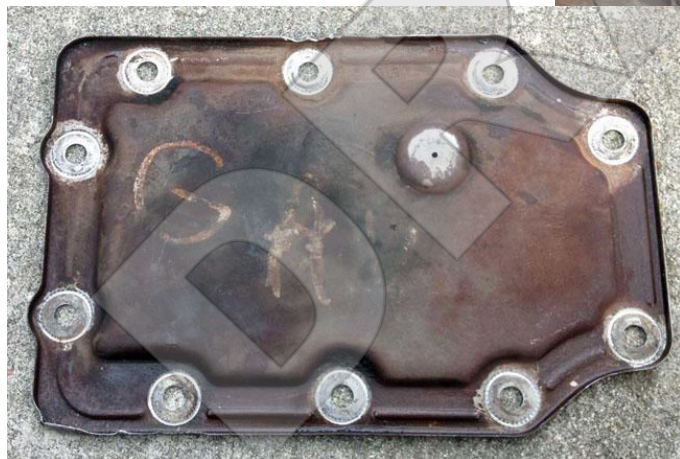
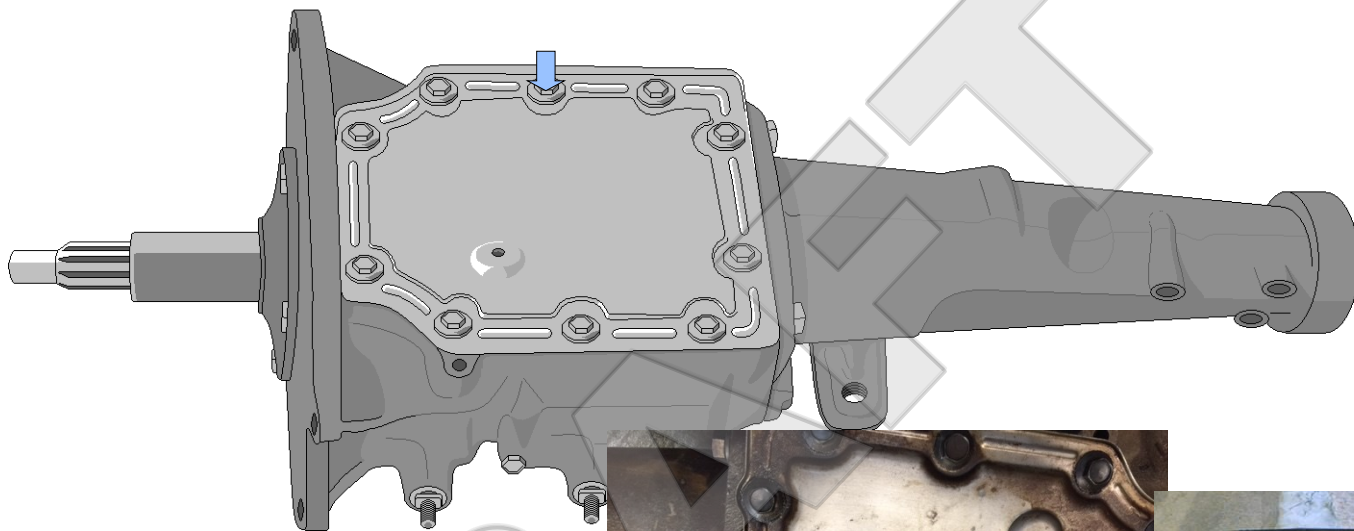



## *In Conclusion*

The purpose of this article was to show and share the markings I've been able to collect over the years. Since we are looking at the subject with a wide view I did not cover all the marks you might possibly find on your unrestored transmission but as mentioned focused on the repetitive and commonly found ones where patterns stand out clearly looking at the examples.

Some of the smaller sub-patterns identified during research for this article were found. On some early models we can find some where the identification stamp was replaced by a hand written identification - possibly the stamp was lost for a period of to. In another period the "G" in some of the identification stamps was damaged or made differently in cross bar area of the stamp.

---

## *In Thanks*

Want to thank the hundreds of car owners and builders for sharing pictures and information about these markings over the years. Only by studying and documenting great numbers of original example can patterns be identified and better understood.